

#prep X Assembly 04: Wire Stand-Offs

[Wire Stand-Offs Overview and Video](#)

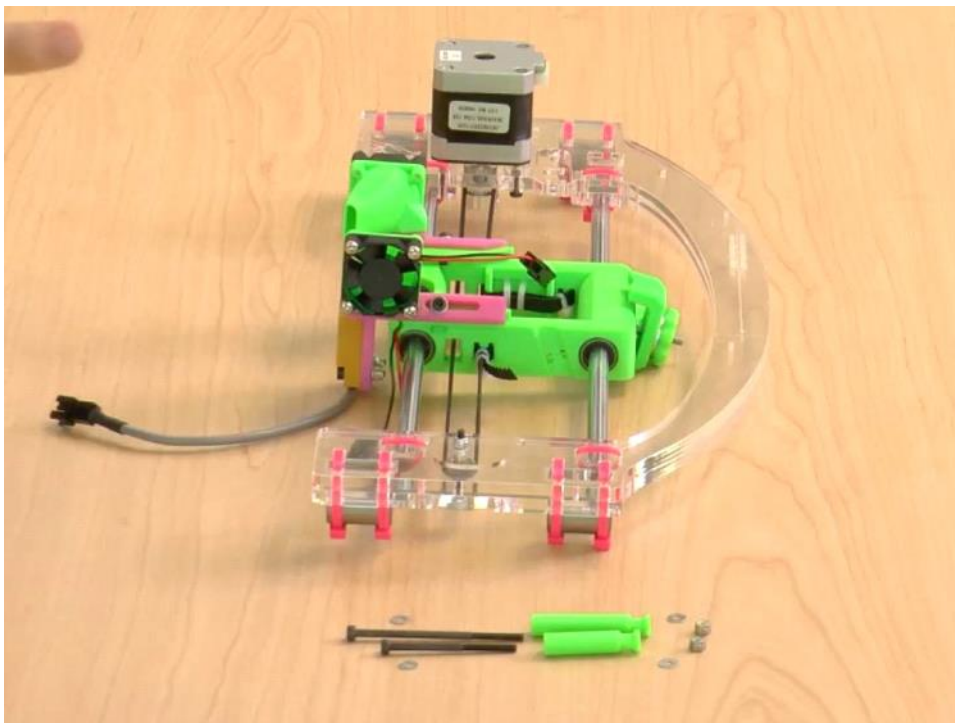

In this video, we prepare two stand-offs = spacers on which we'll then attach all the x assembly wires.

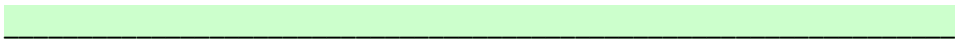

Title: For Attaching the Wire Stand-Offs

You'll Need:

Short Stand-Off(=spacer) (1)

Long Stand-Off (= spacer) (1)

- M3x45 bolt (1)
- M3x60 bolt (1)
- M3 regular washer (4)
- M3 nylon lock nut (2)

Title: The Long Stand-Off

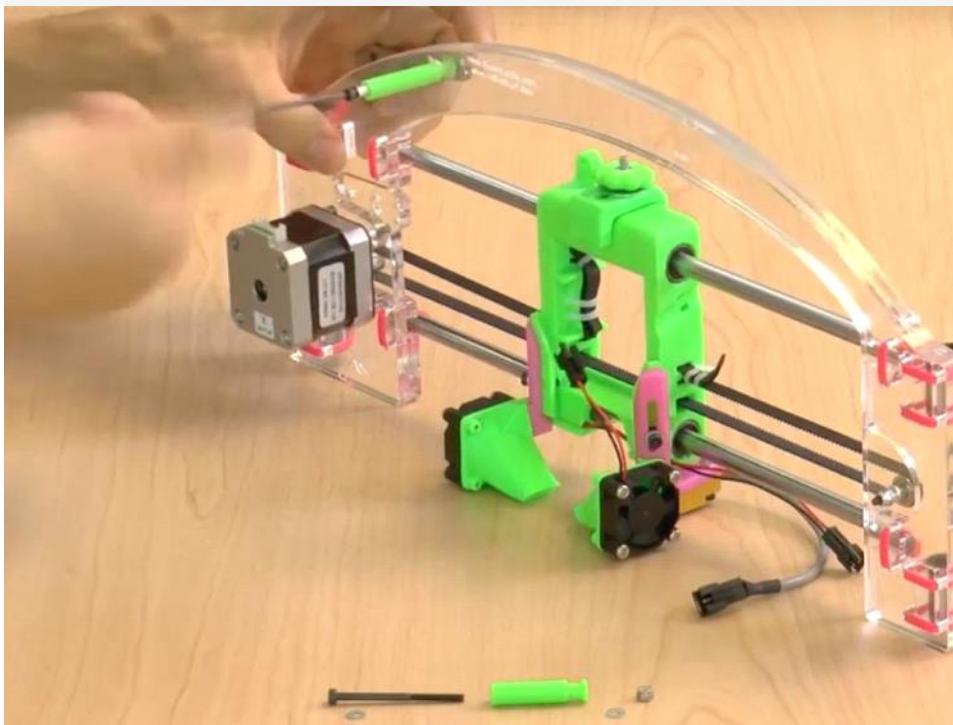
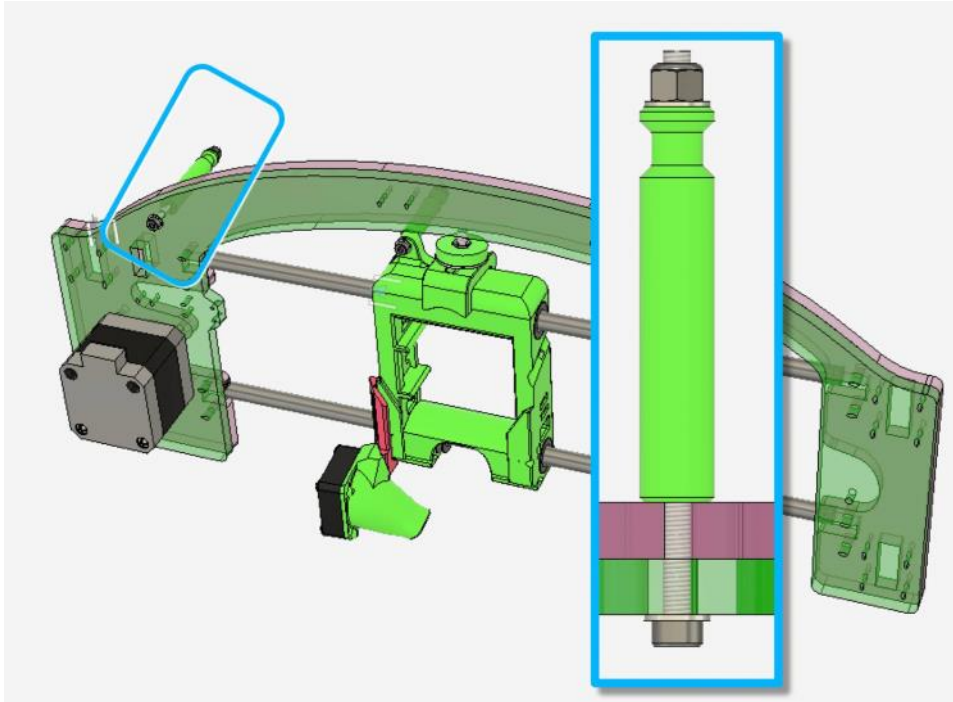

- Order of parts:
- Nylock locknut
 - Regular washer
 - Long green stand-off
 - Acrylic
 - Regular washer

M3x60 screw

Title: The Short Stand-Off

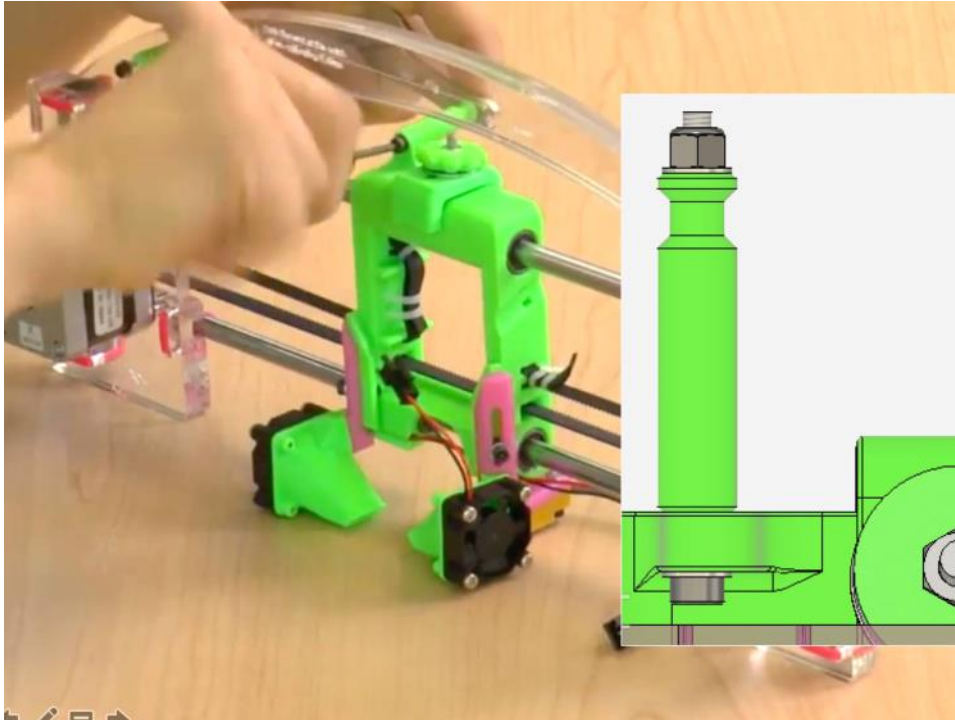

- Order of parts:
Nylock locknut
Regular washer
Long green stand-off
Acrylic
Regular washer
M3x45 screw